

# ***DYNATRAC PRODUCTS***

## **Jeep JK, Dana 44 Heavy Duty Ball Joint Kit**

### **ProSteer Ball Joint Installation Instructions V2.0**

 **WARNING:** This product is designed for use in specified axles and should not be used for custom applications. Any non approved application will risk your safety and the safety of others around you. Any non approved use will void the warranty of the product.

 **WARNING:** Do not use Dynatrac Lower ball joint with use of a camber adjusted upper ball joint.

 **WARNING:** Improper use or installation of this product can cause major failures that could lead to injury or death.

 **WARNING:** There are knock off axle products that are not made to Dana specifications. Dynatrac will not be accountable for the tolerances of non Dana/ Jeep axle products on the market.

**① INFORMATION:** Dynatrac ball joints are sold in a fully assembled condition, ready to install in your vehicle. Install the ball joints as if they are standard OEM replacement parts. Refer to your vehicle or axle service manual or contact a competent auto repair or alignment shop to properly install the ball joints on your vehicle. Press tools are required when installing ball joints, and it is recommended that you use an experienced shop. There are ball joint press tool kits available online, or at auto stores.

For the do it yourself guy, Dynatrac recommends using Miller Press Kit 6289 in conjunction with kit JP44-3050-B supplied by Dynatrac (Fig 9). Other ball joint installation kits besides the listed Miller kit are available; however Dynatrac has not tested them.

**Note:** Dynatrac strongly recommends buying the Dynatrac ball joint installation kit sold separately. The Dynatrac ball joint installation kit will prevent damage to the ball joints during installation.

### **Common Tools Which Will be Required**

- 7/8 Socket
- 15/16 Socket
- Calibrated Torque Wrench
- Pry Bar
- Ball Joint Press Kit, Or Shop Press Equipment (Miller Kit – 6289)
  - C-Clamp (Miller C-4212F)
  - Press Tools (Miller, 6289-1, 6289-3, 6289-4, 6289-5, 6289-12, 8975-2)
  - Should order Miller tool 8975-2 separate from Kit – 6289

## DYNATRAC JK44 PROSTEER INSTALLATION INSTRUCTIONS

- Dynatrac Kit JP44-3050-B
- Wire Brush
- 4 Quarts of Gear Oil (Optional)

### Installation Instructions



**WARNING: Only perform this installation if you are an experienced, fully equipped mechanic.**



**WARNING: Always wear proper safety equipment including safety glasses and gloves while working with tools. Improper use of tools and equipment can cause injury or death.**

### Preparation and Inspection

1. As stated above only perform the installation if you are a fully equipped mechanic. Using the attached bill of materials, verify the kit is complete (Fig 8). Contact Dynatrac if the kit does not include all the listed parts ((714) 596-4461). You may need anywhere between 4 to 10 hours depending on your experience, so allow plenty of time. If you are performing the installation at home, Dynatrac strongly recommends using the Miller ball joint kit with the Dynatrac kit. Dynatrac also recommends using kit number JP44-3050-B with all other installation kits.

### Removing the Knuckle

2. Because there are several axle designs, it is recommended a service manual specific to the vehicle is used. Publications are available online that offer detailed instructions for replacing ball joints.
3. Remove the wheel hub assembly, brakes, tie rod and all other miscellaneous hardware as outlined in the service manual. Once the knuckle is exposed, loosen the two nuts located on the shaft of the upper and lower ball joint. Loosen the lower ball joint nut until 3-5 threads are still on the nut, this will prevent the knuckle from falling off. Since the ball joints have a tapered stud they will be firmly seated in the knuckle. To remove the ball joint stud from the knuckle, use a 5Lb metal hammer to hit the bottom of the end forging. Several hard well directed blows should cause the ball joint stud to fall out of the end forging. At this point you will have the end forging with the ball joints still pressed inside of them.

### Pressing Out Ball Joints

#### Removing the Upper Ball Joint

4. At this point the old ball joints may be pressed out of the end forging (Fig 1). Using the ball joint press kit, remove the upper ball joint first (Miller Tools, C-4212F, 6289-1, 6289-3).

#### Removing the Lower Ball Joint

5. After the upper ball joints have been remove the lower ball joints may be pressed out using Miller Tools, C-4212F, 8975-2, 6289-3 (Fig 2). As stated above tool 8975-2 is not sold in the Miller 6289 kit and needs to be bought separately from Miller.

#### Cleaning the Ball Joint End Forging Bore



Figure 1, Upper Ball Joint Removal



Figure 2, Lower Ball Joint Removal

### Prepping the Ball Joint Bores

6. Once all of the ball joints have been removed, use brake cleaner or another solvent to clean the bores in the knuckle and end forging. It is extremely important to clean any rust or sediment build up off of the end forging faces where the ball joints will seat. If the ball joint bores are not fully cleaned the ball joints may not seat correctly.

### Installing Dynatrac Ball Joints

**⚠ WARNING:** Shop presses exert tremendous force and can easily damage components if caution is not exercised.

**⚠ WARNING:** Pressing on the seal when installing the lower ball joint will damage the seal (Figure 5). Exercise great caution when installing the ball joints to reduce the risk of damage.

### Preparation

7. After the knuckles and end forgings have been cleaned, place Anti-Seize on all the ball joint bodies (Figure 3). There is a significant amount of force required to install the ball joints. Anti-Seize will help prevent galling and damage to the axle components when installed.



Figure 3, Applying Anti Seize to ProSteer Body

### Installation of Lower Ball Joint

8. After the knuckle and end forging have been cleaned, the Dynatrac ball joints may be pressed into the end forging. Start by installing the lower ball joint first (C-4212F, 6289-4, 6289-12, JP44-3050-D). Use the Dynatrac bushing to space the press surface above the seal preventing damage (Fig 4). Clock the grease fitting so it is facing towards the front of the vehicle



Figure 4, Installation of Lower Ball Joint

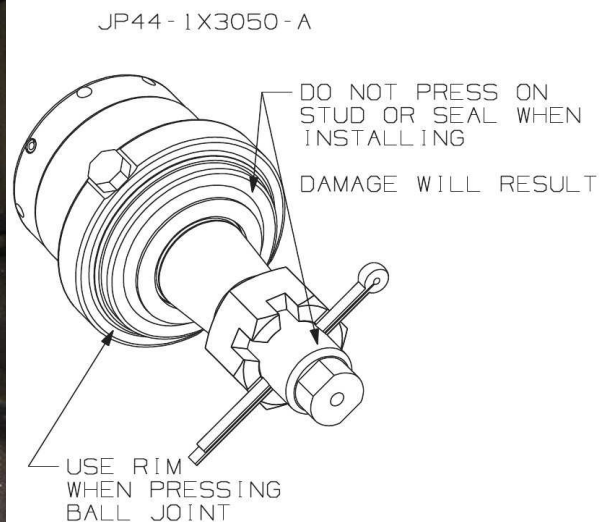

Figure 5, Proper Press Location

### Installation of Upper Ball Joint

9. After the lower ball joint is installed the upper ball joints may be installed using tools C-4212F, 6289-5, 6289-12, CR9.2-3049-K (Fig 6). You may have to remove the E-Clip from the upper ball joint to prevent damaging it when installing the upper ball joint. Use a screw driver to pry the E-Clip off of the upper ball joint (Fig 7). You do not have to remove the thread locker when installing the upper ball joint. After the upper ball joint has been installed remember to put the E-Clip back on.

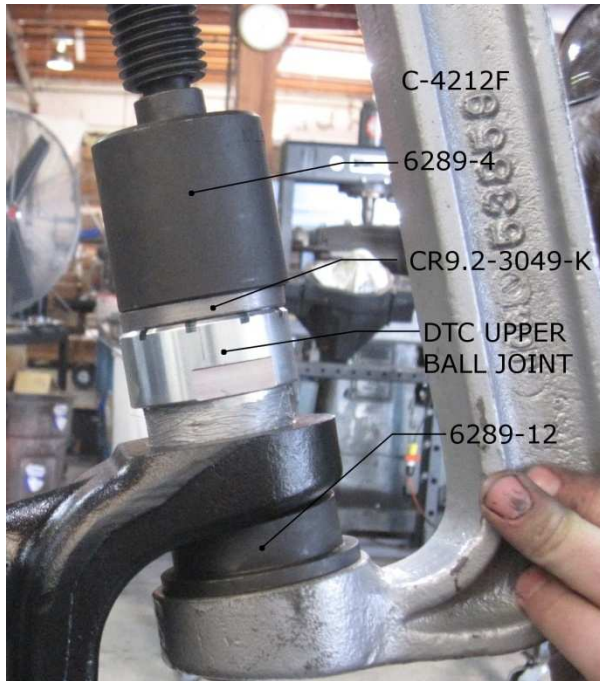

Figure 6, Installation of Upper Ball Joint



Figure 7, Removing E-Clip

### Installation of Knuckle

10. Now the knuckle is ready for installation. A 7/8 socket and a 15/16 socket are required to tighten the ball joint nuts. Be sure to clean the tapered shafts with brake cleaner or acetone; this will help prevent the shaft from spinning during assembly. Place the knuckle into the end forging and lightly screw on the ball joint nuts, preventing the knuckle from sliding out.
11. Once the knuckle has been lightly fastened to the end forging begin to tighten the upper ball joint. The upper ball joint has a shaft that plunges. Use the upper ball joint nut to pull the upper ball joint shaft into the knuckle. This will pull the lower ball joint into the bottom of the knuckle. After the upper ball joint nut has been lightly tightened the lower ball joint nut can be tightened.

### Torque Procedure

- Torque upper ball joint to 35ft. lbs
- Torque lower ball joint to 70 ft. lbs,
- Torque upper ball joint to 70Ft/ lbs, then rotate the castle nut to the next available slot
- Insert cotter pin and fold the tab over
- Re-torque lower ball joint to 105 ft. lbs

- Insert cotter pin and fold the tab over

**Reassembly of Wheel end**

12. At this point the knuckle should be properly bolted to the end forging. Refer to the service manual and reassemble the wheel end. After everything has been installed check the wheel alignment. Make sure the axle is filled with gear oil if the differential was drained prior to disassembly. The knuckle may feel stiff as you move it from side to side; this is common and nothing to worry about.

 **WARNING: Failure to properly refill the axle with Gear Oil can cause serious gear and bearing failure which could result in serious injury or death.**

 **WARNING: Failure to check bolt and lugnut torque can cause serious accident, component failure, serious injury or death.**

**JP44-2X3050-A JK PS Ball Joint Assembly**

<b>Part Number</b>	<b>Description</b>	<b>Qty</b>
JP44-1X3050-A	JK Lower Ball Joint	2
JP44-1X3049-A	JK Upper Ball Joint	2
CR9.2-3049-E	5/8-18 Castle Nut	2
DA60-3049-K	Cotter Pin	4
JP44-3049-E	9/16-18 Castle Nut	2

# DYNATRAC JK44 PROSTEER INSTALLATION INSTRUCTIONS

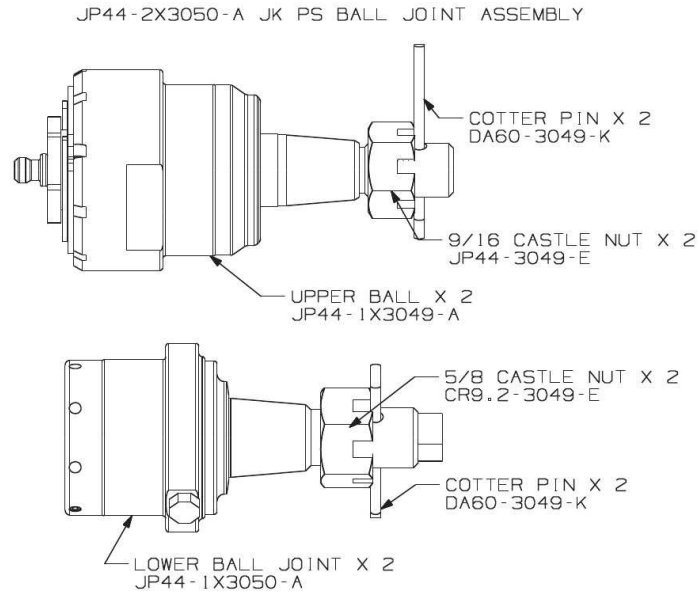

Figure 8, Bill Of Materials

## Additional Installation Kit

Dynatrac strongly recommends buying the additional installation kit for the do it your self guy. It is designed to work with most off the shelf press kits. The bushing kit provides a safe area to press on the ball joint bodies preventing damage to other components.

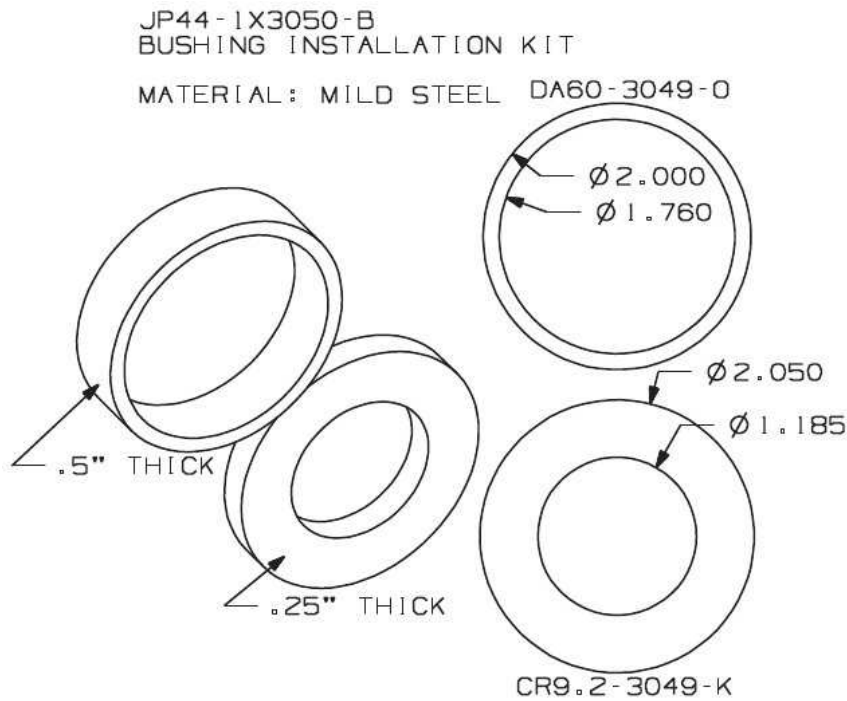

Figure 9, ProSteer Additional Installation Kit